

TK-C210FW/TK-C215V4/
TK-C215V12
DOME CAMERA

JVC

DOME CAMERA

TK-C210FW
TK-C215V4
TK-C215V12

INSTRUCTIONS

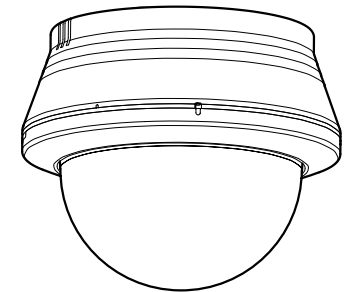

JVC

For Customer Use:

Enter below the Serial No. which is located on the body.
Retain this information for future reference.

Model No. TK-C210FW/TK-C215V4/TK-C215V12

Serial No. _____

Introduction

Safety Precautions



Attention:

This symbol is only valid in the European Union.

Information for Users on Disposal of Old Equipment

[European Union]

This symbol indicates that the electrical and electronic equipment should not be disposed as general household waste at its end-of-life. Instead, the product should be handed over to the applicable collection point for the recycling of electrical and electronic equipment for proper treatment, recovery and recycling in accordance with your national legislation.

By disposing of this product correctly, you will help to conserve natural resources and will help prevent potential negative effects on the environment and human health which could otherwise be caused by inappropriate waste handling of this product. For more information about collection point and recycling of this product, please contact your local municipal office, your household waste disposal service or the shop where you purchased the product.

Penalties may be applicable for incorrect disposal of this waste, in accordance with national legislation.

[Business users]

If you wish to dispose of this product, please visit our web page www.jvceurope.com to obtain information about the take-back of the product.

[Other Countries outside the European Union]

If you wish to dispose of this product, please do so in accordance with applicable national legislation or other rules in your country for the treatment of old electrical and electronic equipment.

FOR USA AND CANADA

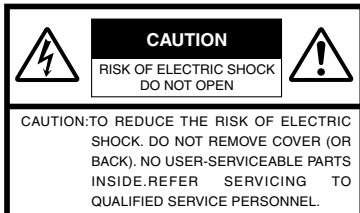

The lightning flash with arrowhead symbol, within an equilateral triangle is intended to alert the user to the presence of uninsulated "dangerous voltage" within the product's enclosure that may be of sufficient magnitude to constitute a risk of electric shock to persons.



The exclamation point within an equilateral triangle is intended to alert the user to the presence of important operating and maintenance (servicing) instructions in the literature accompanying the appliance.



Due to design modifications, data given in this instruction book are subject to possible change without prior notice.

WARNING:
TO REDUCE THE RISK OF FIRE OR ELECTRIC SHOCK, DO NOT EXPOSE THIS APPLIANCE TO RAIN OR MOISTURE.

AVERTISSEMENT:
POUR EVITER LES RISQUES D'INCENDIE OU D'ELECTROCUTION, NE PAS EXPOSER L'APPAREIL A L'HUMIDITE OU A LA PLUIE.

INFORMATION (FOR CANADA) RENSEIGNEMENT (POUR CANADA)

This Class B digital apparatus complies with Canadian ICES-003.

Cet appareil numérique de la Class Best conforme a la norme NMB-003 du Canada.

INFORMATION FOR USA

■ INFORMATION

This equipment has been tested and found to comply with the limits for a Class B digital device, pursuant to Part 15 of the FCC Rules.

These limits are designed to provide reasonable protection against harmful interference in a residential installation. This equipment generates, uses, and can radiate radio frequency energy and, if not installed and used in accordance with the instructions, may cause harmful interference to radio communications. However, there is no guarantee that interference will not occur in a particular installation.

If this equipment does cause harmful interference to radio or television reception, which can be determined by turning the equipment off and on, the user is encouraged to try to correct the interference by one or more of the following measures:

- Reorient or relocate the receiving antenna.
- Increase the separation between the equipment and receiver.
- Connect the equipment into an outlet on a circuit different from that to which the receiver is connected.
- Consult the dealer or an experienced radio/TV technician for help.

■ CAUTION

CHANGES OR MODIFICATIONS NOT APPROVED BY JVC COULD VOID USER'S AUTHORITY TO OPERATE THE EQUIPMENT.

THIS DEVICE COMPLIES WITH PART 15 OF THE FCC RULES. OPERATION IS SUBJECT TO THE FOLLOWING TWO CONDITIONS: (1) THIS DEVICE MAY NOT CAUSE HARMFUL INTERFERENCE, AND (2) THIS DEVICE MUST ACCEPT ANY INTERFERENCE RECEIVED, INCLUDING INTERFERENCE THAT MAY CAUSE UNDESIRABLE OPERATION.

- The unit is to be powered by a DC 12 V or an AC 24 V power supply.
- The unit is to be powered by a UL Listed DC 12 V or an AC 24 V power supply. (For U type)
- The AC 24 V and 12 V DC power supply shall conform to the following: Class 2 only (For USA), Isolated power supply only (For Europe).

- This installation should be made by a qualified service person and should conform to all local codes.
- This installation shall be in accordance with the National Electrical Code, ANSI/NFPA 70.
- Any Mention in this manual of Alarm inputs have not been evaluated by UL to be used for Burglar Alarm Functionality.
- Embedding of cameras in the ceiling may not be allowed due to regulations in some regions. Please consult your nearby authorized JVC dealer for more details.
- The ceiling to mount the camera has to be strong enough to support the weight of this product. If the ceiling is not strong enough, make sure to apply reinforcement to the ceiling before installation.
- Be sure to tighten the screws and nuts securely. Insufficient tightening may cause the unit to fall from its mount.
- The rating label is displayed on the side of the camera unit.
- The camera unit may fall if the mounting screws and nuts are not properly tightened. Ensure that the screws and nuts are properly tightened.
- We do not accept liability for any damage to the camera in cases when it is dropped because of incomplete installation due to not observing the installation instructions correctly. Please be careful when installing the camera.
- Do not install the camera near lighting equipment with a high temperature, such as spotlights. Doing so may cause malfunction or fire.

- Before starting an important recording, be sure to perform a test recording in order to confirm that a normal recording is possible.
- We will not provide any compensation whatsoever for the contents to be recorded or loss of opportunities when recording is not properly performed due to malfunction of the video camera, VTR, hard disk recorder or video tape.
- Prior to adjusting the shooting direction of the camera, touch the metal surface of the [MONITOR] terminal with your hand to discharge static electricity from your body.

Introduction (continued)

These are general **IMPORTANT SAFEGUARDS** and certain items may not apply to all appliances.

IMPORTANT SAFEGUARDS

1. Read all of these instructions.
2. Save these instructions for later use.
3. All warnings on the product and in the operating instructions should be adhered to.
4. Unplug this appliance system from the wall outlet before cleaning. Do not use liquid cleaners or aerosol cleaners. Use a damp cloth for cleaning.
5. Do not use attachments not recommended by the appliance manufacturer as they may cause hazards.
6. Do not use this appliance near water - for example, near a bathtub, washbowl, kitchen sink, or laundry tub, in a wet basement, or near a swimming pool, etc.
7. Do not place this appliance on an unstable cart, stand, or table. The appliance may fall, causing serious injury to a child or adult, and serious damage to the appliance. Use only with a cart or stand recommended by the manufacturer, or sold with the appliance. Wall or shelf mounting should follow the manufacturer's instructions, and should use a mounting kit approved by the manufacturer. An appliance and cart combination should be moved with care. Quick stops, excessive force, and uneven surfaces may cause the appliance and cart combination to overturn.
8. Slots and openings in the cabinet and the back or bottom are provided for ventilation, and to insure reliable operation of the appliance and to protect it from overheating, these openings must not be blocked or covered. The openings should never be blocked by placing the appliance on a bed, sofa, rug, or other similar surface. This appliance should never be placed near or over a radiator or heat register. This appliance should not be placed in a built-in installation such as a bookcase unless proper ventilation is provided.
9. This appliance should be operated only from the type of power source indicated on the marking label. If you are not sure of the type of power supplied to your home, consult your dealer or local power company. For appliance designed to operate from battery power, refer to the operating instructions.
10. For added protection for this product during a lightning storm, or when it is left unattended and unused for long periods of time, unplug it from the wall outlet and disconnect the antenna or cable system. This will prevent damage to the product due to lightning and power-line surges.
11. Do not allow anything to rest on the power cord. Do not locate this appliance where the cord will be abused by persons walking on it.
12. Follow all warnings and instructions marked on the appliance.
13. Do not overload wall outlets and extension cords as this can result in fire or electric shock.
14. Never push objects of any kind into this appliance through cabinet slots as they may touch dangerous voltage points or short out parts that could result in a fire or electric shock. Never spill liquid of any kind on the appliance.
15. Do not attempt to service this appliance yourself as opening or removing covers may expose you to dangerous voltage or other hazards. Refer all servicing to qualified service personnel.
16. Unplug this appliance from the wall outlet and refer servicing to qualified service personnel under the following conditions:
 - a. When the power cord or plug is damaged or frayed.
 - b. If liquid has been spilled into the appliance.
 - c. If the appliance has been exposed to rain or water.
 - d. If the appliance does not operate normally by following the operating instructions. Adjust only those controls that are covered by the operating instructions as improper adjustment of other controls may result in damage and will often require extensive work by a qualified technician to restore the appliance to normal operation.
 - e. If the appliance has been dropped or the cabinet has been damaged.
 - f. When the appliance exhibits a distinct change in performance - this indicates a need for service.
17. When replacement parts are required, be sure the service technician has used replacement parts specified by the manufacturer that have the same characteristics as the original part. Unauthorized substitutions may result in fire, electric shock, or other hazards.
18. Upon completion of any service or repairs to this appliance, ask the service technician to perform routine safety checks to determine that the appliance is in safe operating condition.

PORTABLE CART WARNING
(symbol provided by RETAC)



Thank you for purchasing this product.
(These instructions are for: TK-C210FWE,
TK-C215V4U/E, TK-C215V12U/E.)

Before beginning to operate this unit, please read the instruction manual carefully in order to make sure that the best possible performance is obtained.

Characteristics

Realizing a High Picture Quality

This camera realizes 540 TV lines* and S/N50 dB* by employing a highly sensitive CCD with 380,000 pixels and a high-resolution video processing circuit.

* 500 TV lines and 48 dB in the case of TK-C210FW

Enlarged Shooting Range

The adjustment range of the shooting direction is wide and mounting of the camera to the wall is possible with the employment of 3 axis rotation mechanism.

Non Camera-Like Design

Dome-type design allows application in various locations.

Embedding in Ceiling Without Use of Metal Fittings

There is no need to use a separate recess bracket when embedding this camera to the ceiling.

High Magnification Varifocal/Zoom Lens

(TK-C215V4 and TK-C215V12 only)
The built-in x3.6 varifocal lens (TK-C215V4) and x12 zoom lens (TK-C215V12) enables detailed supervision.

Alarm Zoom Feature (TK-C215V12 only)

2 preset positions are available, which allow setting of the monitoring screen size under normal circumstances and during alarm input.

Easy DAY & NIGHT Feature (TK-C215V4 and TK-C215V12 only)

A Easy DAY & NIGHT feature is available, which switches automatically to a black-and-white image when the object is dark. This is useful for supervision in a dark environment.

This instruction manual covers total 5 different models in common as follows;

TK-C215V4U
TK-C215V4E
TK-C215V12U
TK-C215V12E
TK-C210FWE

In this manual, each model number is described without the last letter (U / E) which means the shipping destination. (U: NTSC , E: PAL)

Only "U" models (TK-C215V4U and TK-C215V12U) have been evaluated by UL.

How to Use This Manual

Characters and symbols used in this manual

CAUTION : Points to pay attention to during operation.

NOTE : Details for reference, such as functions or constraints during use.

EST : Pages or items to refer to.

• All product names that appear in this document are the trademarks or registered trademarks of their respective companies. Marks and symbols such as TM, ® and ® do not appear in this document.

Introduction (continued)

Contents

Introduction

Safety Precautions	2
Characteristics	5
Contents	6
Operating Precautions	7
Name of Parts	8
Camera	8
Camera (Interior)	9
Setting the Lens and Switches (TK-C215V4)	10
Setting the Lens and Switches (TK-C215V12)	12
Setting the Lens and Switches (TK-C210FW)	14

Installation and connection

About Connection Cables	14
Video signal cables	14
Installing the Ferrite core (TK-C210FW only)	14
DC 12 V or AC 24 V power supply cable	15
Electrical Specifications of Alarm Input Terminals	15
System diagram	16
Mounting the Camera to the Ceiling	17
Getting Started	17
Selecting a mounting method	17
Embedding the camera to the ceiling	18
When mounting the camera directly to the ceiling or on the wall	20
When mounting the camera to the electrical box	22
Mount by allowing the cable to exit from the side	22

Adjusting Image

Adjusting Images	23
Mounting the test monitor	23
Adjusting the camera direction	23
Adjusting the field angle/focus/ brightness	24
Mounting the Dome Cover	26
White-spot correction	27

Others

Specifications	28
----------------------	----

Operating Precautions

- To save energy, when it is not being used turn the system's power off.
- This camera has been designed for indoor use. It cannot be used outdoors.
- Do not install or use the camera in the following places.
 - In a place exposed to rain or moisture.
 - In a place with vapor or oil soot, for example in a kitchen.
 - In a temperature outside the operating temperature range (−10 °C to 50 °C).
 - Near a source of radiation, X-rays, strong radio waves or magnetism.
 - In a place where corrosive gasses are generated.
 - In a place subject to vibration.
 - In a place with excessive dirt.
 - In an environment where there is cold air or near the air outlet of an air conditioner.
- If this camera and the cables connected to this camera are used where there are strong electromagnetic waves or where there is magnetism present, for example near a radio or TV transmitter, power transformer or an electric motor, the picture may produce noise and the colors may be affected.
- This camera incorporates an AGC circuit. As a result, when it is used under low light conditions, the camera sensitivity is automatically boosted and the picture may look uneven. This is not a malfunction however.
- When this camera is used in the ATW mode, the recorded colors may be slightly different from the actual colors due to the operational principles of the auto-tracking white balance circuit. This is however not a malfunction.
- If a high-intensity object (such as a lamp) is shot, the image on the screen may have vertical lines (smear) or blur (blooming) at its periphery. This is a characteristic of the CCD, and is not a defect.
- Observe the following when carrying out camera maintenance.
- Turn the power OFF before proceeding to carry out maintenance.
- Clean the dome cover lens using a lens wiper cloth (or a tissue). If it is contaminated seriously, clean the contaminated part with a cloth (or a tissue) which has been soaked in a solution of water and a neutral detergent.
- If the DAY/NIGHT switch is turned on, the mode changes automatically to black and white in dark places. As the sensitivity increases, the image may look grainy and white spots may appear. When changing modes, bright portions of image may be emphasized but this is not a failure of the camera. (TK-C215V4/TK-C215V12 only)
- When the supply voltage of the camera is low, the input protection circuit within the camera may be triggered and the power of the camera may turn off automatically. Make sure to use a supply voltage for the camera that is within -10 % of the rated voltage.
- Upon switching between the HOME and ALARM positions, the camera focus may change slightly after the zoom operation comes to a stop. This is due to the built-in lens performance and is not a malfunction. (TK-C215V12 only)
- When the camera is moved from a cold area to room temperature, condensation may occur causing the camera to malfunction as a result. In this case, turn on the power after waiting for a few hours.
- This unit enlarges the rotation angle to support wide range set up. For TK-C215V4 and TK-C215V12, when the zoom of the lens is set to WIDE end and the tilt angle is set around $\pm 80^\circ$, the dome cover can be visible into the image depending on the rotation angle. In this case, adjust the image angle if necessary. (☞ pg. 23)
- All Interconnecting Equipment must be UL Listed.

■ Note on consumable parts (TK-C215V12 only)

The following parts are consumable and should be replaced after a certain number of hours or a count of operations. The service lives given below are only typical values. They may vary depending on the operating environment and conditions. Note that the replacement of consumable parts is chargeable even when they are replaced before the termination of the warranty period.

- Zoom lens assembly
- Zooming operation: 2 million times

Introduction (continued)

Name of Parts

Camera

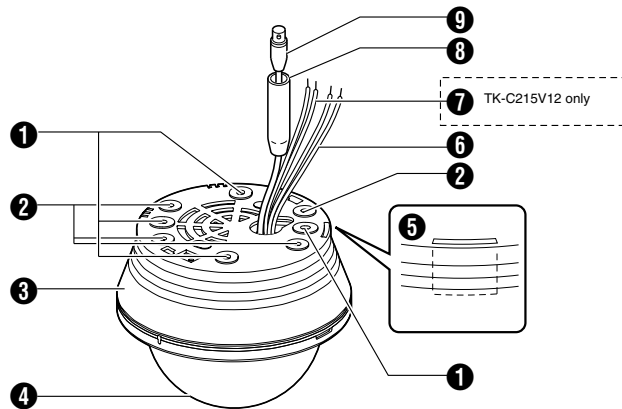

1 Mounting hole (elliptical) x 4

Use these when mounting the camera to the electrical box. (☞ pg. 22)

NOTE:

When installing the camera onto the electric box, install it using the supplied adaptor ring.

2 Mounting hole (round) x 4

Use these when mounting the camera to the ceiling or wall. (☞ pg. 18, 20)

3 Outer Case

Use this in the following cases:

- When mounting the camera directly to the ceiling or on the wall. (☞ pg. 20)
- When mounting the camera to the electrical box. (☞ pg. 22)

4 Dome Cover

The dome cover is fragile. Take care when handling it.

5 Wiring Hole

Break and use this when drawing the cable from the camera unit without drilling a hole in the ceiling. (☞ pg. 22)

6 Input Power cable

DC 12 V Input: Red (+12 V), Black (GND)
AC 24 V Input: Non-polar. (☞ pg. 15)

7 Alarm signal cable (TK-C215V12 only)

Yellow (ALARM IN), Gray (ALARM GND).
(☞ pg. 15)

8 Protection Cover

Upon connecting the coaxial cable, protect it by insulating the metal part of the BNC connector from the ceiling structure.

9 Video signal output connector (BNC)

(☞ pg. 14)

Camera (Interior)

The picture below shows the camera when the dome cover and outer case are removed. Procedures for removal. (☞ pg. 18 "Embedding the camera to the ceiling", Step 3. to Step 4.)

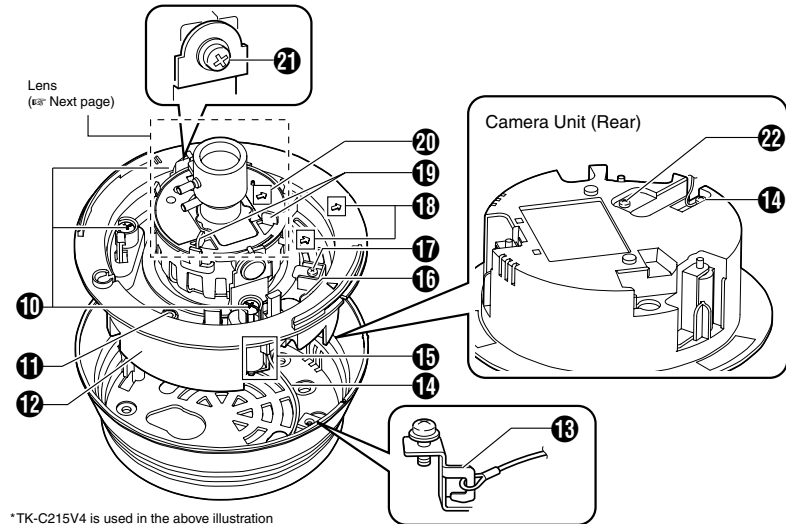

10 Fastening Screw (x 3)

Screw head of the ceiling mount bracket **15** to be used when embedding the camera to the ceiling.

11 [MONITOR] terminal (RCA pin)

(☞ pg. 23)

12 Camera Unit

13 Fall Prevention Wire Fastening Hook

14 Fall Prevention Wire (Supplied) and Wire Mounting Screw

Connect the camera unit **12** and the outer case **3** using the fall prevention wire fastening hook **13**.

15 Ceiling Mount Bracket (x 3)

This is used as a bracket when embedding the camera to the ceiling. (☞ pg. 18)

16 Camera Fastening Screw

Use this to fasten the camera unit **12** to the outer case **3**. To remove. (☞ pg. 18, 20)

17 Tilt Lock screw

Tighten the screw to ensure that camera's shooting direction does not go out of alignment when it is used in a location with strong vibration. (☞ pg. 24)

18 Imaging Direction mark

Install the camera by aligning the imaging direction with the arrow mark.

19 Rotation Knob

Rotate the lens unit to adjust the inclination of the image (to be turned).

20 Rotation Center Mark

(☞ pg. 24)

21 Pan fastening Screw

Ensure to loosen the screw before setting. Further tighten the screw to ensure that camera's shooting direction does not go out of alignment only when it is used in a location with strong vibration. (☞ pg. 24)

22 Fall Prevention Wire mounting hole & Screw

(Fall Prevention Wire not included.)

Introduction (continued)

Setting the Lens and Switches (TK-C215V4)

Set the video setting switches on the camera unit before mounting it.

To set the switches, use a fine-tipped screwdriver.

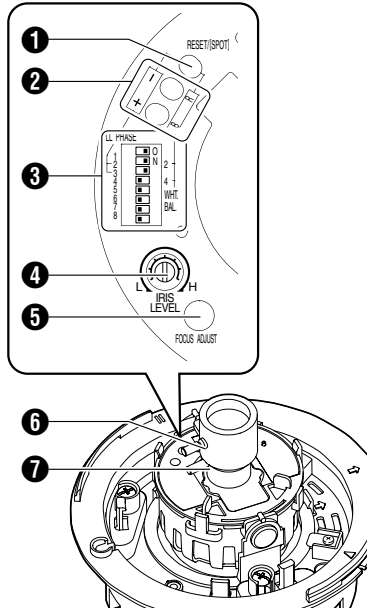

Function selection switch setting table
(Items in bold are factory position)

	OFF <input type="checkbox"/>	<input type="checkbox"/> ON
1 AGC	OFF	ON
2 SELECT	PHASE	WHT. BAL.
3 SYNC	LL	INT
4 WHT. BAL.	ATW	MANU
5 BLC	OFF	ON
6 DAY/NIGHT	OFF	ON
7 RESERVED	<input checked="" type="checkbox"/> SET TO OFF	
8 RESET/SPOT	RESET	SPOT

1 [RESET/SPOT] RESET/SPOT button

When this button is pressed, the value of the white balance or phase adjusted manually is reset to the default value.

- When the 2 [SELECT] switch is set to WHT. BAL., the white balance is reset to the default value.
When the switch is set to PHASE, the phase is reset to the default value.
- When setting to SPOT:
When this button is pressed, white spots are corrected.
For instructions on correcting white spots, see "White-spot correction" (pg. 27).

2 [R/B, +/-] R/B, +/- adjustment button

This button is pressed when manually adjusting the white balance or when adjusting the vertical phase of the line lock. The function of this button is selected using the 2 [SELECT] switch.

- When manually adjusting the white balance:
Press the R button to increase the red tint and decrease the blue tint.
Press the B button to increase the blue tint and decrease the red tint.
- When adjusting the phase:
Press the + or - button to adjust the phase.

3 Function selection switches

1. [AGC] Auto-gain control switch.

Setting this switch to "ON" automatically increases the sensitivity even when the brightness of the subject is insufficient. (Default setting: ON)

2. [SELECT] WHT. BAL./PHASE setting switch.

WHT. BAL.:
The 2 [R/B, +/-] buttons are used as [R/B] adjustment buttons.

PHASE:
The 2 [R/B, +/-] buttons are used as [+/-] adjustment buttons. (Default setting: WHT. BAL.)

3. [SYNC] Synchronization system selection switch.

This switch sets the synchronizing system for the camera.

INT:

This is set for internal synchronization

LL (Line Lock):

The camera's vertical synchronization is locked to the AC 24 V power line frequency. When switching between multiple cameras using a switcher, selecting this mode and adjusting the vertical phase can reduce the monitor sync disturbances occur that when the camera image is switched.

U type: 60 Hz only

E type: 50 Hz only

(Default setting: INT)

4. [WHT. BAL.] ATW/MANUAL selection switch.

For selecting whether to adjust the white balance automatically or manually.

When the setting is changed from manual to ATW, the setting values in the manual mode will be reset. The camera switches to the same mode as with pressing the [RESET] button. (Default setting: ATW)

NOTE:

- The white balance of this camera is preset to use under sunlight or halogen lamps, and may not be properly adjusted when used under artificial lights such as fluorescent lights.

5. [BLC] Backlight compensation switch.

When the object is placed against the light, setting this to "ON" increases the iris aperture by 1 stop and the object will appear clearer. (Default setting: OFF)

6. [DAY/NIGHT] Easy Day & Night switch.

To capture a subject with continually changing brightness (day/night), set this switch to "ON". The camera automatically captures the image in color when the subject is bright, and in black and white mode when it is dark. (Default setting: OFF)

NOTE:

- When this item is set to "ON", the AGC feature will automatically be set to "ON" regardless of the [AGC] Switch 1 setting.
- The Easy DAY & NIGHT feature on this camera uses a sensitized black and white mode unlike other black and white surveillance cameras that use infra-red lighting.
- Sensitivity increases in the case of black-and-white images. The screen may

therefore appear rougher and white spots may increase.

7. [RESERVED]

Not used. Ensure to set this to "OFF" before using the camera. (Default setting: OFF)

8. [RESET/SPOT] RESET/SPOT CORRECTION selection switch.

RESET:

The [RESET/SPOT] button is used as a [RESET] button.

SPOT:

The [RESET/SPOT] button is used as a [SPOT] button. (pg. 27) (Default setting: RESET)

4 [IRIS LEVEL] Iris level adjustment

For adjusting the level of the automatic aperture control lens. This adjustment only needs to be made when required. Use this to accommodate particular shooting conditions. To darken image: Counterclockwise (L side) To brighten image: Clockwise (H side)

NOTE:

Prior to adjusting the aperture level, ensure to set the [AGC] Switch 1 of the function selection switch 1 to "OFF". Otherwise, when the level is turned too far toward L, the AGC function activates increasing sensitivity and the picture may look uneven.

5 [FOCUS ADJUST] focus adjustment button

Use this to adjust the lens focus. Upon pressing, the lens aperture will open up for about 30 seconds such that the depth of field becomes shallower, thus enabling focus to be easily adjusted. (pg. 25)

NOTE:

The electronic shutter functions automatically upon pressing the focus adjustment button and the screen may flicker. However, this is not a malfunction.

6 Focus adjustment ring

Move this to the left/right to adjust the focus.

7 Zoom adjustment ring

Move this to the left/right to adjust the field angle.

Introduction (continued)

Setting the Lens and Switches (TK-C215V12)

Set the video setting switches on the camera unit before mounting it.

To set the switches, use a fine-tipped screwdriver.

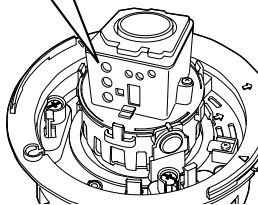
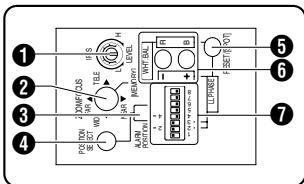

Function selection switch setting table
(Items in bold are factory position)

	OFF <input type="checkbox"/>	<input type="checkbox"/> ON
1 AGC	OFF	ON
2 SELECT	PHASE	WHT.BAL.
3 SYNC	LL	INT
4 WHT.BAL.	ATW	MANUAL
5 BLC	OFF	ON
6 DAY/NIGHT	OFF	ON
7 ALARM	TRIGGER	STATE
8 RESET/SPOT	RESET	SPOT

1 [IRIS LEVEL] Iris level adjustment

For adjusting the level of the automatic aperture control lens. This adjustment only needs to be made when required. Use this to accommodate particular shooting conditions. To darken image: Counterclockwise (L side) To brighten image: Clockwise (H side)

NOTE:

Prior to adjusting the aperture level, ensure to set the 1 [AGC] Switch of the function selection switch 7 to "OFF". Otherwise, when the level is turned too far toward L, the AGC function activates increasing sensitivity and the picture may look uneven.

2 [ZOOM/FOCUS, MEMORY] zoom, focus adjustment switches/position memory button

Use the [▲TELE] and [▼WIDE] switches to zoom, and the [◀FAR] and [▶NEAR] switches to adjust focus. (☞ pg. 25)
Press the [MEMORY] button to register the position. (☞ pg. 25)

3 [ALARM POSITION] status indication LED

Light off : Registration of home position is enabled
Light on (red) : Lens initializing.
Light on (green): Registration of alarm position is enabled
Blinking (green): Position memory registration mode → memory registration completed (☞ pg. 25)

4 [POSITION SELECT] POSITION SELECT button

Press this button to switch between the home and alarm positions. Display on the status indication LED 3 will change accordingly. (☞ pg. 25)

5 [RESET/SPOT] RESET/SPOT button

When this button is pressed, the value of the white balance or phase adjusted manually is reset to the default value.

- When the 2 [SELECT] switch is set to [WHT.BAL.], the white balance is reset to the default value.
When the switch is set to PHASE, the phase is reset to the default value.
- When setting to SPOT:
When this button is pressed, white-spots are corrected.
For instructions on correcting white-spots, see "White-spot correction" (☞ pg. 27).

6 [R/B, +/-] R/B, +/- adjustment button

This button is pressed when manually adjusting the white balance or when adjusting the vertical phase of the line lock.

The function of this button is selected using the 2 [SELECT] switch.

- When manually adjusting the white balance:
Press the R button to increase the red tint and decrease the blue tint.
Press the B button to increase the blue tint and decrease the red tint.
- When adjusting the phase:
Press the + or - button to adjust the phase.

7 Function selection switches

1. [AGC] Auto-gain control switch.

Setting this switch to "ON" automatically increases the sensitivity even when the brightness of the subject is insufficient. (Default setting: ON)

2. [SELECT] WHT.BAL./PHASE setting switch. WHT.BAL.:

The 6 [R/B, +/-] buttons are used as [R/B] adjustment buttons.

PHASE:

The 6 [R/B, +/-] buttons are used as [+/-] adjustment buttons. (Default setting: WHT.BAL.)

3. [SYNC] Synchronization system selection switch.

This switch sets the synchronizing system for the camera.

INT:

This is set for internal synchronization

LL (Line Lock):

The camera's vertical synchronization is locked to the AC 24 V power line frequency. When switching between multiple cameras using a switcher, selecting this mode and adjusting the vertical phase can reduce the monitor sync disturbances occur that when the camera image is switched.

U type: 60 Hz only

E type: 50 Hz only
(Default setting: INT)

4. [WHT.BAL.] ATW/MANUAL selection switch.

For selecting whether to adjust the white balance automatically or manually. When the setting is changed from manual to ATW, the setting values in the manual mode will be reset. The camera switches to the same mode as with pressing the [RESET] button.

NOTE:

- The white balance of this camera is preset to use under sunlight or halogen lamps, and may not be properly adjusted when used under artificial lights such as fluorescent lights.

(Default setting: ATW)

5. [BLC] Backlight compensation switch.

When the object is placed against the light, setting this to "ON" increases the iris aperture by 1 stop and the object will appear clearer. (Default setting: OFF)

6. [DAY/NIGHT] Easy DAY & NIGHT switch.

To capture a subject with continually changing brightness (day/night), set this switch to "ON" The camera automatically captures the image in color when the subject is bright, and in black and white mode when it is dark. (Default setting: OFF)

NOTE:

- When this item is set to "ON", the AGC feature will automatically be set to "ON" regardless of the [AGC] Switch 1 setting.
- The Easy DAY & NIGHT feature on this camera uses a sensitized black and white mode unlike other black and white surveillance cameras that use infra-red lighting.
- Sensitivity increases in the case of black-and-white images. The screen may therefore appear rougher and white spots may increase.

7. [ALARM] alarm input mode selection switch.

For setting the lens movement when there is an alarm input. Set according to the alarm device that you are using. (☞ pg. 15 "Electrical Specifications of Alarm Input Terminals") (☞ pg. 23 "Adjusting Images")

TRIGGER:

Upon input of an alarm, the lens moves to the preset zoom/focus position (alarm position). The lens remains in the alarm position for 15 seconds before it returns automatically to the home position. When there is a new alarm input while the lens is at the alarm position, the lens continues to remain in the alarm position for 15 seconds upon the last alarm input.

STATE:

Upon input of an alarm, the lens moves to the preset zoom/focus position (alarm position). The lens remains in the alarm position for 15 seconds. The lens will, after a lapse of 15 seconds, continue shooting at the alarm position as long as there is alarm input. The lens returns automatically to the home position immediately after alarm input stops. (Default setting: TRIGGER)

8. [RESET/SPOT] RESET/SPOT correction selection switch.

RESET:

The [RESET/SPOT] button 8 is used as a [RESET] button.

SPOT:

The [RESET/SPOT] button 8 is used as a [SPOT] button. (☞ pg. 27)
(Default setting: RESET)

Installation and connection

Setting the Lens and Switches (TK-C210FW)

Set the video setting switches on the camera unit before mounting it.
To set the switches, use a fine-tipped screwdriver.

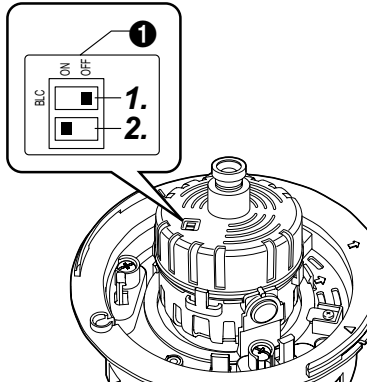

1. Function selection switches

1. [BLC] Backlight compensation switch.

When the object is placed against the light, setting this to "ON" increases the iris aperture by 1 stop and the object will appear clearer. (Default setting: OFF)

2. Service switch.

Ensure to set to "ON".

About Connection Cables

The maximum connection distance varies with the type of cable used. Please refer carefully to the table for each cable during connection.

* Be sure to turn off the power of devices before connecting cables.

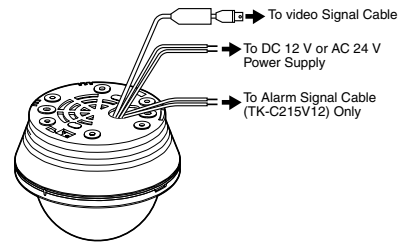

Video signal cables

Connect the coaxial cables (BNC) to the video signal output connector (BNC).

Cable	Maximum extension (No cable compensator)
RG-59	200 m
RG-6	350 m
RG-11	450 m

Installing the Ferrite core (TK-C210FW only)

In order to reduce the influence to the screen caused by the noise induced from the cable, wind both Video signal cable and Input power supply cable once to the supplied Ferrite core.

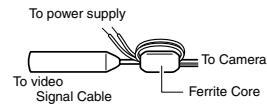

DC 12 V or AC 24 V power supply cable

Connect the DC 12 V or the AC 24 V power supply to the DC 12 V/AC 24 V terminals on the terminal board. To prevent connection errors or a cable disconnection, we recommend the use of lug plates for the connections. The following table shows the connection distances and connection cables provided that 2-conductor VVF cables (vinyl-insulated vinyl sheath cables) are used.

		Conductor diameter (mm)		
		φ 1.0 mm (AWG18)	φ 1.6 mm (AWG14)	φ 2.0 mm (AWG12)
TK-C210FW Maximum extension	DC12V	80 m (260ft)	210 m (680ft)	340 m (1100ft)
	AC24V	210 m (680ft)	540 m (1700ft)	860 m (2800ft)
TK-C215V4 Maximum extension	DC12V	50 m (160ft)	140 m (450ft)	220 m (720ft)
	AC24V	130 m (420ft)	350 m (1100ft)	550 m (1800ft)
TK-C215V12 Maximum extension	DC12V	30 m (90ft)	80 m (260ft)	130 m (420ft)
	AC24V	80 m (260ft)	210 m (680ft)	340 m (1100ft)

CAUTION:

- If thin cables are used (i.e. with a high resistance), a significant voltage drop will occur when the unit is at its maximum power consumption. Either use a thick cable to restrict the voltage drop at the camera side to below 10 %, or place the power supply near to the camera. When the voltage is low, the protection circuit within the camera may be triggered and the power of the camera may turn off automatically.
- Do not allow input from both a DC 12 V and AC 24 V power supply at the same time.
- When using a DC 12 V power supply, ensure that the polarities of the cable are correct.
- The AC 24 V power supply should conform to the following:
U-type: Class 2 only
E-type: Isolated power supply only

Electrical Specifications of Alarm Input Terminals

(TK-C215V12 only)

- To prevent penetration of noise in the internal circuitry, apply a non-voltage contact signal to the ALARM input terminal. Never apply a voltage.
- Apply an alarm signal for at least 200 ms. If it is shorter, it is not guaranteed that the signal will be recognized as an alarm signal.
- Under the alarm status (status when the metal contact is "make"), select the contact or connecting wire such that the maximum wire resistance between the ALARM IN and ALARM GND is within 150 Ω.

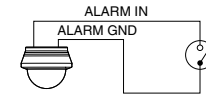

◆ Polarity of alarm signals

ALARM INPUT	
SHORT (CONTACT)	ALARM
OPEN	NORMAL (HOME POSITION)

Installation and connection (continued)

System diagram

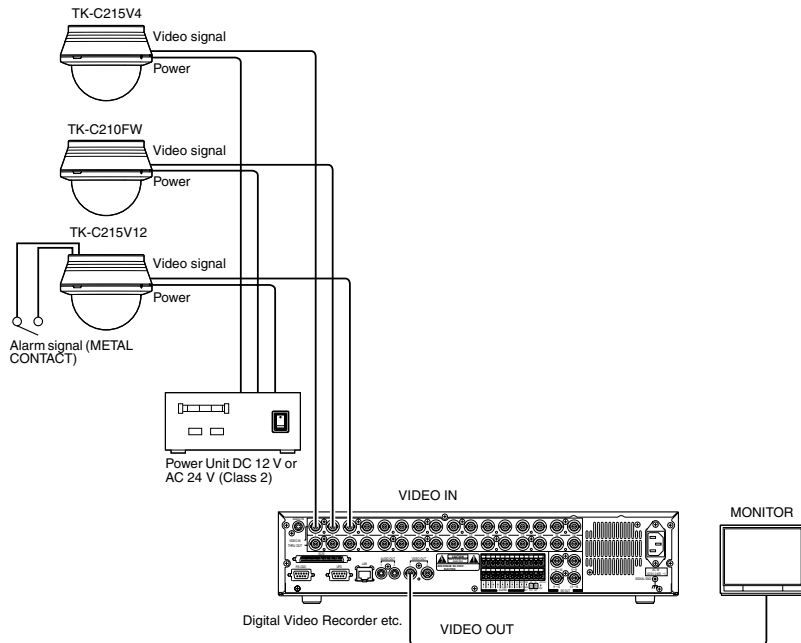

NOTE:

- Turn OFF the power supply to all equipment to be used before making connections.
- Read the Instruction Manual for each piece of equipment to be used before making connections.

CAUTION:

Power consumption of TK-C210FW/TK-C215V4/TK-C215V12 are different from one another. When installing a mixture of these models, select a cable length according to the power consumption of each model. Alternatively, install based on the model with the highest power consumption.

Mounting the Camera to the Ceiling

Getting Started

CAUTION:

- When mounting the camera to the ceiling, ensure to wear safety glasses to protect the eye from any falling object.
- Attachment of an embedded cover in the ceiling (recess bracket) may be mandatory in certain regions. If this is so, ensure that the embedded cover (recess bracket) is securely attached before installing the camera.
- Please refer to the instruction manual for the cover in use for details on installation of the embedded cover (recess bracket).
- For more detail, please contact the JVC.

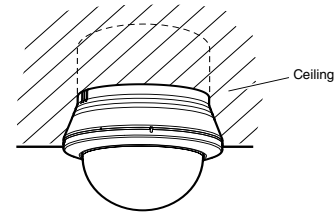

Embedded Cover in Ceiling (recess bracket)

Selecting a mounting method

Select a method for mounting the camera according to the intended purpose.

- ◆ “Embedding the camera to the ceiling” (☞ pg. 18)
- ◆ “When mounting the camera directly to the ceiling or on the wall” (☞ pg. 20)
- ◆ “When mounting the camera to the electrical box” (☞ pg. 22)
- ◆ “Mount by allowing the cable to exit from the side” (☞ pg. 22)

Installation and connection (continued)

Mounting the Camera to the Ceiling (continued)

Embedding the camera to the ceiling

* Make use of a ceiling material with a thickness between 9.5 mm to 22 mm.

■ Setup

1. Open a hole in the ceiling. (ø120 mm)
2. Draw the fall prevention wire mounted to the ceiling slab and the cable out from the ceiling in advance.

CAUTION:

- Select a suitable safety cable based on length, strength, location, material (insulation property), etc.
- Use a ring on the fall prevention wire for mounting to the camera unit with an internal diameter of at least ø3.1 mm or and not larger than ø5.5 mm, and an external diameter that is not larger than ø9 mm.

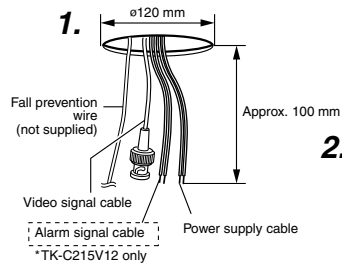

3. Remove the dome cover.

As illustrated in the diagram, hold the dome ring such that the position mark comes between the thumb and index finger. Turn the ring in the anti-clockwise direction to remove.

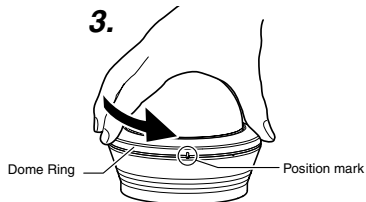

4. Remove the outer case.

(This method does not require an outer case.)

- ① Loosen the outer case fastening screw with a screwdriver
- ② To remove, turn the camera unit in the anti-clockwise direction

5. Dismantle the supplied fall prevention wire

Unfasten the mounting screw for the fall prevention wire at the rear of the camera unit

6. Loosen the pan fastening screw.

CAUTION:

Moving the lens unit without loosening the pan fastening screw may damage the lens unit.

7. Set the switches for video images.

(TK-C215V4 [☞](#) pg. 10)
(TK-C215V12 [☞](#) pg. 12)
(TK-C210FW [☞](#) pg. 14)

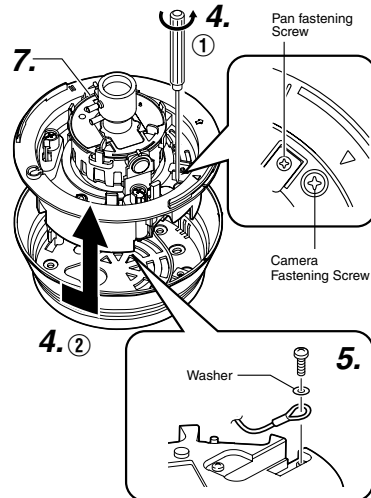

*TK-C215V4 is used in the above illustration

■ Connecting

1. Attach the fall prevention wire to the camera, followed by attaching it to the ceiling slab (Fall prevention wire is not included.)
2. Connect the video signal cable. ([☞](#) pg. 14)
Lower the cover and connect the connectors. Upon connecting, cover the connectors using the protection cover.
3. Connect the input power supply cable. ([☞](#) pg. 15)
4. Install the Ferrite core (TK-C210FW only) ([☞](#) pg. 14)
5. Connect the alarm cable. (TK-C215V12 only) ([☞](#) pg. 15)
6. Wrap insulation tape around cables.
7. Insert the camera unit into the ceiling hole.

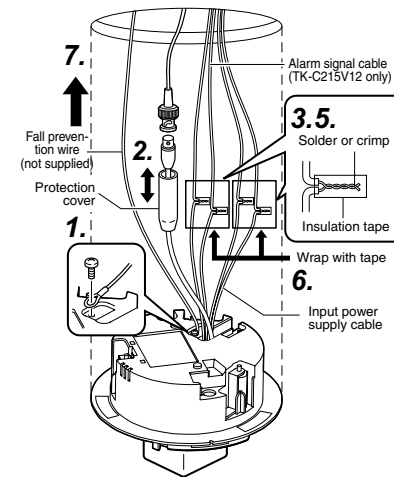

*TK-C215V12 is used in the above illustration

■ Mounting

1. Align with the shooting direction when mounting the camera.

2. Fasten the camera. (x3 locations)

- ① Press the screw head of the clamping bracket all the way in using a cross screwdriver.
- ② With the screw pressed in using the screwdriver, turn about 90° in the clockwise direction, followed by pulling out the screwdriver.
- ③ The clamping bracket is attached to the ceiling and the camera fastened.

NOTE:

Dismantle the camera upon turning the screw heads of the ceiling mount bracket (x3) by 90° in the anti-clockwise direction.

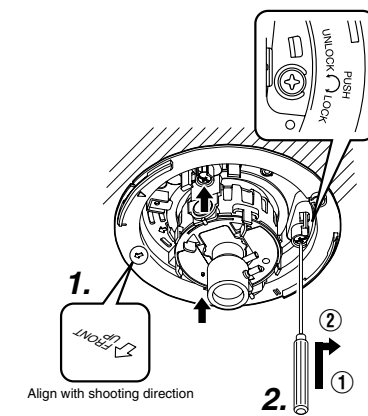

*TK-C215V4 is used in the above illustration

■ Adjusting Images

After mounting is completed, adjust the images while checking the actual image. ([☞](#) pg. 23 "Adjusting Images")

Installation and connection (continued)

Mounting the Camera to the Ceiling (continued)

When mounting the camera directly to the ceiling or on the wall

When mounting to a wall, replace areas indicated as "ceiling" in the procedures by "wall".

■ Setup

- 1. Open a hole in the ceiling. (ø30 mm)**
Make use of the template supplied to open a hole.
- 2. Draw the fall prevention wire mounted to the ceiling slab and the cable out from the ceiling in advance.**

CAUTION:

- Select a suitable safety cable based on length, strength, location, material (insulation property), etc.
- Use a ring on the fall prevention wire for mounting to the camera unit with an internal diameter of at least ø3.1 mm or and not larger than ø5.5 mm, and an external diameter that is not larger than ø9 mm.

- 3. Remove the dome cover.**

As illustrated in the diagram, hold the dome ring such that the position mark comes between the thumb and index finger. Turn the ring in the anti-clockwise direction to remove.

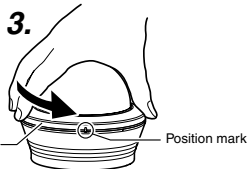

- 4. Remove the outer case.**

- ① Loosen the camera fastening screw with a screwdriver.
- ② To remove, turn the camera unit in the anti-clockwise direction.
- ③ Dismantle the fall prevention wire.

- 5. Loosen the pan fastening screw.**

CAUTION:

- Moving the lens unit without loosening the pan fastening screw may damage the lens unit.

- 6. Set the switches for video images.**
(TK-C215V4 ☞ pg. 10)
(TK-C215V12 ☞ pg. 12)
(TK-C210FW ☞ pg. 14)

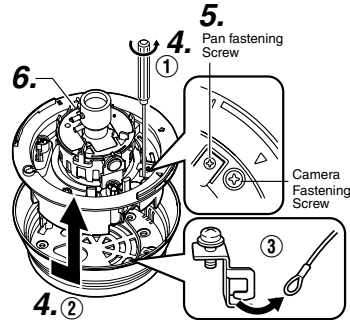

*TK-C215V4 is used in the above illustration

■ Connecting

- 1. Align ↑ with the shooting direction when mounting the cover to the ceiling.**
Mount by using the supplied adaptor ring to clamp between the outer case and the ceiling.

Notes on outer case mounting screws (not supplied):

- The diameter of the attachment hole of outer case is ø4.5 mm (3/16 inch).
- Do not use flathead screws.
- When using an impact screwdriver, do not tighten the screws fully. Tighten using your hand instead. Failure to do so may damage the outer case.

- 2. Hang the fall prevention wire that has been dismantled in Step 4 ③ of the setup procedures to the hook.**

- 3. Attach the fall prevention wire to the camera.**
(Fall prevention wire is not included)

CAUTION:

- Tighten all screws securely. Otherwise the camera may come loose and fall.

Installation and connection (continued)

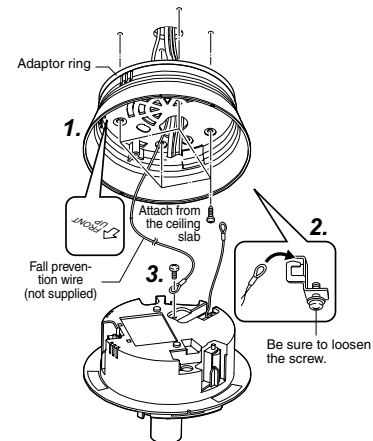

*TK-C215V4 is used in the above illustration

- 4. Connect the video signal cable. (☞ pg. 14)**

Lower the protection cover and connect the connectors. Upon connecting, restore the protection cover to cover the connectors.

- 5. Connect the input power supply cable. (☞ pg. 15)**

- 6. Install the Ferrite core (TK-C210FW only) (☞ pg. 14)**

- 7. Connect the alarm cable. (TK-C215V12 only) (☞ pg. 15)**

- 8. Wrap insulation tape around cables.**

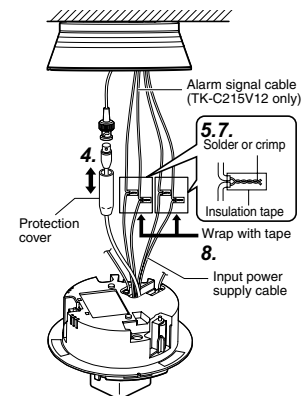

*TK-C215V12 is used in the above illustration

■ Mounting

- 1. Align the position mark of the fastened outer case with that of the camera unit.**

NOTE:

When doing so, be careful not to catch the cables in the outer case.

- 2. Turn the camera unit in the clockwise direction.**

* When doing so, ensure that the ○ mark is visible. (See illustration below)

- 3. Fasten the camera by tightening the camera fastening screw.**

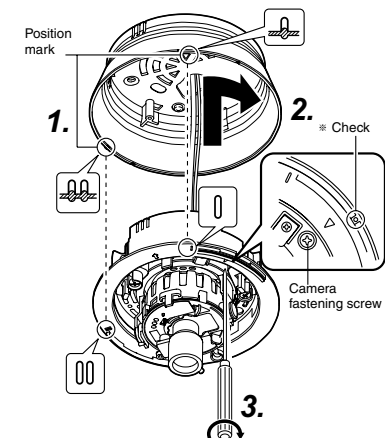

*TK-C215V4 is used in the above illustration

■ Adjusting Images

After mounting is completed, adjust the images while checking the actual image. (☞ pg. 23 "Adjusting Images")

Installation and connection (continued)

Mounting the Camera to the Ceiling (continued)

When mounting the camera to the electrical box

NOTE:

Before mounting the camera to electrical boxes, please consult your nearby JVC authorized dealer for details on the type of electrical box for which mounting is possible.

■ Connecting

1. Align  with the shooting direction when mounting the cover to the electrical box.

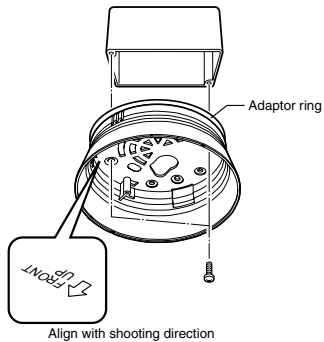

2. Follow steps 2 to 7 of "When mounting the camera directly to the ceiling or on the wall" (■ Connecting) (pg. 20).

■ Mounting

1. Attach the camera to the outer case that has been fastened to the electrical box.

Follow steps 1 to 3 of "When mounting the camera directly to the ceiling or on the wall" (■ Mounting) (pg. 21)

■ Adjusting Images

After mounting is completed, adjust the images while checking the actual image. (pg. 23 "Adjusting Images")

Mount by allowing the cable to exit from the side

When mounting the camera to the ceiling or a wall, it is possible to guide the cable from the side without opening any holes.

The basic mounting method is identical to steps in "When mounting the camera directly to the ceiling or on the wall" (pg. 20).

1. Break the cable extraction hole using a pair of long-nose pliers

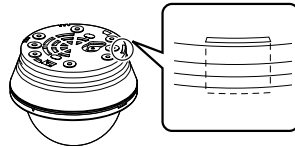

2. Pull out the cable from the extraction hole and mount it to the ceiling or wall

3. Connecting the cable

Follow steps 4 to 7 of "When mounting the camera directly to the ceiling or on the wall" (■ Connecting) (pg. 21)

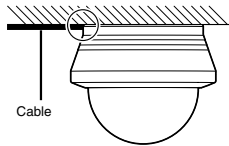

4. Adjusting Images

After mounting is completed, adjust the images while checking the actual image. (pg. 23 "Adjusting Images")

Adjusting Image

Adjusting Images

Upon mounting the camera, adjust the images while checking the actual image.

Mounting the test monitor

Connect the [MONITOR] terminal of this camera to a test monitor to adjust the camera's shooting direction, image and focus.

* The power to the camera body must be ON when adjustments are performed.

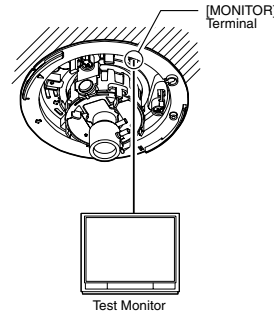

*TK-C215V4 is used in the above illustration

CAUTION:

The TK-C210FW monitor produces a high impedance output. Do not terminate the test monitor. Allow it to remain open during connection. When a test monitor that cannot be left open is connected to this terminal, the picture level when connected to the video signal output connector may deteriorate and appear dark. However, this is not a malfunction. TK-C215V4/V12 output at an impedance of 75 Ω.

Adjusting the camera direction

The camera unit can be adjusted horizontally or vertically and rotated. Adjust the camera in the direction of the object.

CAUTION:

- Please discharge a static electricity by touching to a [MONITOR] Terminal by hand before adjust the angle of view.
- Before adjusting the shooting direction of the camera, ensure that the pan fastening screw is loosened. Moving the lens unit without loosening the pan fastening screw may damage the lens unit.

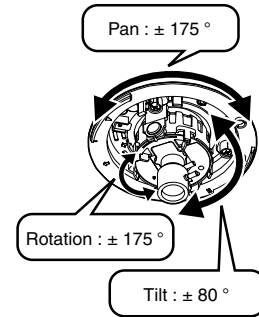

*TK-C215V4 is used in the above illustration

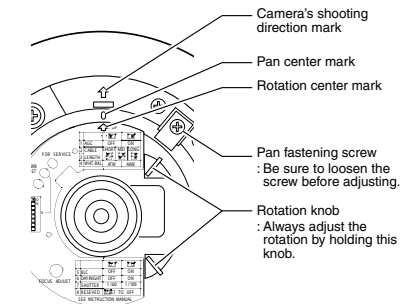

NOTE:

- Pan rotation of $\pm 175^\circ$ is possible from each of the camera's shooting direction mark, pan center mark and rotation center mark. When adjusting the rotation, do not hold the lens unit. Always adjust by holding the rotation knob.
- When using the camera at locations with strong vibration, stabilize by tightening the tile fastening screw and pan fastening screw to prevent distortion of the camera's field angle.

CAUTION:

- Moving the camera beyond its adjustable range may cause failure in maintaining the performance of this camera.
- As this camera has a wide tilt/rotation range, a part of this camera may appear on the screen depending on the field angle and orientation.
- Do not hold the lens unit when adjusting the direction of the camera. Applying force on the lens unit may damage it.

Adjusting Image (continued)

Adjusting the field angle/focus/ brightness

(Not available on TK-C210FW)

Upon determining the imaging direction, adjust the field angle, focus and iris level accordingly. The method of adjustment varies with the camera in use.

◆ TK-C215V4 (☞ pg. 24)

◆ TK-C215V12 (☞ pg. 25)

■ TK-C215V4

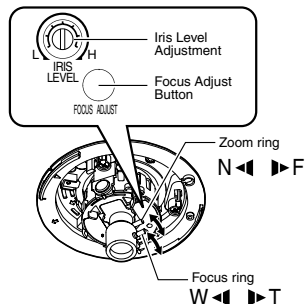

*TK-C215V4 is used in the above illustration

Adjusting field angle

Loosen the fastening screw for the zoom adjustment ring and move the ring to the left/right to adjust the image.

Adjusting focus

Press the FOCUS ADJUST button. The iris will be opened for 30 seconds. Loosen the fastening screw for the focus adjustment ring and move the ring to the left/right to align the focus.

NOTE:

- Set by repeating "Adjusting field angle" and "Adjusting focus" for 2 to 3 times. After adjustment is completed, fasten by tightening each of the fastening screws.
- The electronic shutter functions automatically upon pressing the focus adjustment button and the screen may flicker. However, this is not a malfunction.

Adjusting brightness

This adjustment only needs to be made when required. Use this to accommodate particular shooting conditions.

To darken image : Counterclockwise (L side)
To brighten image : Clockwise (H side)

NOTE:

- For adjusting the brightness, do not conduct it within 30 seconds after pressing the focus button.
- When adjusting the iris level, set the AGC switch to "OFF". Otherwise, when the level is turned too far toward L, the AGC function activates increasing sensitivity and the picture may look uneven.

Adjusting Images (continued)

■ TK-C215V12

- 2 types of angle of view may be selected for TK-C215V12. In general, set in a way such that the home position shoots a wide range and the alarm position a narrow range.
- Use the alarm input mode selection switch to set the actions when there is an alarm input. (☞ pg. 13)

CAUTION:

- When setting images on TK-C215V12, ensure that the lens is covered using the dome cover. This camera is equipped with a high magnification lens. When adjustment is not performed through the cover, the lens may go out of focus when the cover is attached.
- When adjusting the focus, ensure that the optical axis of the lens and the center of the dome cover are aligned, and that the screen is not distorted. (See illustration below)

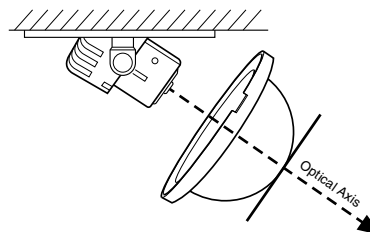

◆ Registering home position

For registering the angle of view during monitoring under normal conditions.

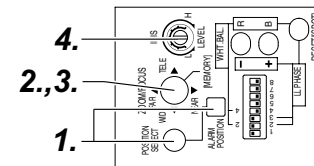

1. Check that the [ALARM POSITION] indicator light is turned off.

Registration of home position is enabled. Press the [POSITION SELECT] button if the [ALARM POSITION] indicator light is on.

2. Adjust the angle of view.

① Adjust the field angle

Move the zoom adjustment switch in the [TELE] or [WIDE] direction to adjust the field angle.

② Adjust the focus

Move the focus adjustment switch in the [NEAR] or [FAR] direction to adjust the focus.

NOTE:

When the [ZOOM/FOCUS] switch is set to either [TELE/WIDE] or [NEAR/FAR], the iris will automatically open up for about 30 seconds and focus can be easily adjusted. During this interval, the electronic shutter mode is activated and the image may flicker. However, this is not a malfunction.

3. Press the [MEMORY] button for 2 seconds or longer.

The [ALARM POSITION] indicator light blinks for 3 times (green)

4. Adjust the brightness.

This adjustment only needs to be made when required. Use this to accommodate particular shooting conditions.

To darken image : Counterclockwise (L side)
To brighten image : Clockwise (H side)

NOTE:

- For adjusting the brightness, do not conduct it within 30 seconds after pressing the [ZOOM/FOCUS] button.
- When adjusting the iris level, set the AGC switch to "OFF". Otherwise, when the level is turned too far toward L, the AGC function activates increasing sensitivity and the picture may look uneven.



Home position registration is completed

Adjusting Image (continued)

Adjusting Images (continued)

◆ Registering alarm position

For registering the angle of view during monitoring when there is an alarm input.

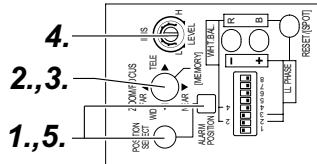

1. Check that the [ALARM POSITION] indicator light is turned on.

Registration of alarm position is enabled.

- Press the [POSITION SELECT] button if the [ALARM POSITION] indicator light is off.

2. Adjust the image size. (see pg. 25)

3. Press the [MEMORY] button for 2 seconds or longer.

The [ALARM POSITION] indicator light blinks for 3 times (green)



ALARM position registration is completed

4. Adjust the brightness. (see pg. 25)

5. Press the [POSITION SELECT] button.

The camera returns to the home position

NOTE:

- Be sure to return the camera to the home position after registration of the alarm position is completed.
In addition to pressing the [POSITION SELECT] button, you can also use the power ON/OFF button to return the camera to the home position.
- To check images at the registered home position or alarm position, press the [POSITION SELECT] button. Press this button to switch between the image at the home and alarm positions.

Mounting the Dome Cover

After setting is complete, mount the dome cover.

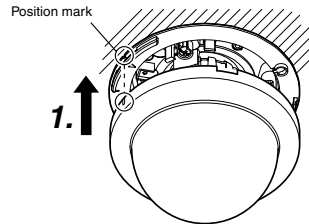

1. Mount the dome cover.

Align the position marks on the camera unit and dome cover, followed by pressing in directly to mount the cover.

CAUTION:

Press the dome over until a “click” sound is heard. Check that the cover is firmly mounted. Failure to mount the cover firmly may cause this cover to fall off.

White-spot correction

As a general characteristic unique to CCDs, white-spots may appear on the screen with age. In order to reduce this phenomenon, this unit is equipped with a white-spot correction feature. Switch on the camera power supply and wait for at least 30 minutes.

(Not available on TK-C210FW)

◆ TK-C215V4

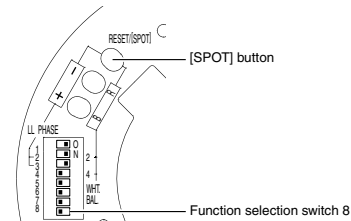

◆ TK-C215V12

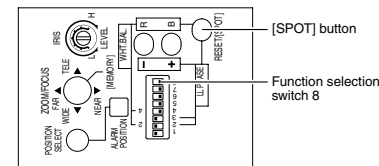

1. Remove the dome cover.

2. Cover the lens surface using a black sheet of paper, etc. so that light does not enter the lens.

3. Set the function selection switch 8 to [SPOT]. (see pg. 11, 13)

4. Press and hold the SPOT CORRECTION button for more than 2 seconds.

- White-spot correction will start. Correction may take several seconds for completion.

NOTE:

- Maximum correction: less than 16 to 32 spots
- The white-spot correction feature of this unit does not guarantee the correction of all white spots.
Depending on the characteristic of white spots, correction may not be possible.
- When performing white-spot correction, accurate data may not be achieved in case of highly detailed pixels since correction is made using the information of surrounding pixels.
- The result of white-spot correction is maintained until the next correction is performed.

Others

Specifications

■ Camera

Signal system:

U type : Based on NTSC standard
E type : Based on PAL standard

Scanning frequencies

U type : 15.734 kHz (Horizontal),
59.94 Hz (Vertical)
E type : 15.625 kHz (Horizontal),
50 Hz (Vertical)

Image device: 1/4" IT CCD

Effective picture elements:

U type : 380,000 pixels,
768 (H) x 494 (V)
E type : 440,000 pixels,
752 (H) x 582 (V)

Sync system

TK-C210FW : Internal
TK-C215V4/TK-C215V12
: Line lock/Internal

Video S/N:

TK-C210FW : 48 dB (AGC OFF, white 50 %
output)
TK-C215V4/TK-C215V12
: 50 dB (AGC OFF, white 50 %
output)

Horizontal resolution:

TK-C210FW : 500 TV lines (Center, Typ.)
TK-C215V4/TK-C215V12
: 540 TV lines (Center, Typ.)

Minimum illumination: (Typical)

TK-C210FW : 7.5 lx (F2.0 AGC ON,
50%,with smoke cover)
2.7 lx (F2.0 AGC ON,
25%,with smoke cover)
1.3 lx (F2.0 AGC ON, 25 %,
with optional clear cover)

TK-C215V4

Color mode : 5.6 lx (F1.3 AGC ON,
50%,with smoke cover)
2.1 lx (F1.3 AGC ON,
25%,with smoke cover)
0.9 lx (F1.3 AGC ON, 25%,
with optional clear cover)

Black and White mode

: 3.6 lx (F1.3 AGC ON,
50%,with smoke cover)
1.3 lx (F1.3 AGC ON,
25%,with smoke cover)
0.6 lx (F1.3 AGC ON, 25%,
with optional clear cover)

TK-C215V12

Color mode : 8.3 lx (F1.6 AGC ON,
50%,with smoke cover)
2.9 lx (F1.6 AGC ON,
25%,with smoke cover)
1.3 lx (F1.6 AGC ON, 25%,
with optional clear cover)

Black and White mode:

4.9 lx (F1.6 AGC ON,
50%,with smoke cover)
1.6 lx (F1.6 AGC ON,
25%,with smoke cover)
0.8 lx (F1.6 AGC ON, 25%,
with optional clear cover)

White balance:

TK-C210FW : ATW
Color temperature range
2900K to 8000K

TK-C215V4/TK-C215V12

: ATW/Manual (Switchable)
Color temperature range
2300K to 10000K

Backlight compensation

: ON/OFF (Switchable)

Easy DAY & NIGHT

(TK-C215V4/TK-C215V12 only)
: ON/OFF (Switchable)

■ Lens

Focal length

TK-C210FW : 2.9 mm
TK-C215V4 : 2.8 mm to 10 mm (variable)
TK-C215V12 : 3.8 mm to 45.6 mm (variable)

Zoom ratio

TK-C215V4 : Approx. 3.6
TK-C215V12 : Approx. 12

Maximum aperture

TK-C210FW : F2.0
TK-C215V4 : F1.3 (f = 2.8 mm) to F3.0
(f = 10 mm)
TK-C215V12 : F1.6 (f = 3.8 mm) to F2.7
(f = 45.6 mm)

Angle adjustment range

Pan : ±175 °
Rotation : ±175 °
Tilt : ±80 °

Angle of vision

TK-C210FW : 71 ° (H) x 53 ° (V)
TK-C215V4 : f = 2.8 mm
73 ° (H) x 54 ° (V)
f = 10 mm
20 ° (H) x 15 ° (V)
TK-C215V12 : f = 3.8 mm
52 ° (H) x 39 ° (V)
f = 45.6 mm
4.5 ° (H) x 3.4 ° (V)

■ General

Power supply : U type : AC 24 V 60 Hz
DC 12 V
E type : AC 24 V $\sqrt{}$ 50 Hz/60 Hz
DC 12 V \equiv

Power consumption

TK-C210FW:
E type : 220 mA
TK-C215V4:
U type : 4.2 W
E type : 340 mA
TK-C215V12:
U type : 6.6 W
E type : 550 mA

Ambient temperature

: -10 °C to 50 °C
(14 °F to 122 °F) (Operation)
: 0 °C to 40 °C
(32 °F to 104 °F) (Recommended)

Mass

TK-C210FW : Approx. 450 g
TK-C215V4 : Approx. 470 g
TK-C215V12 : Approx. 530 g

Accessories

U type:
Instructions 1
Warranty Card 1
Service Information Card 1
Template 1
Adaptor ring 1
E type:
Instructions 1
Template 1
Adaptor ring 1
Ferrite Core (TK-C210FW only) 1

